

# **X**TREMPRO

*Our loader just got better!*

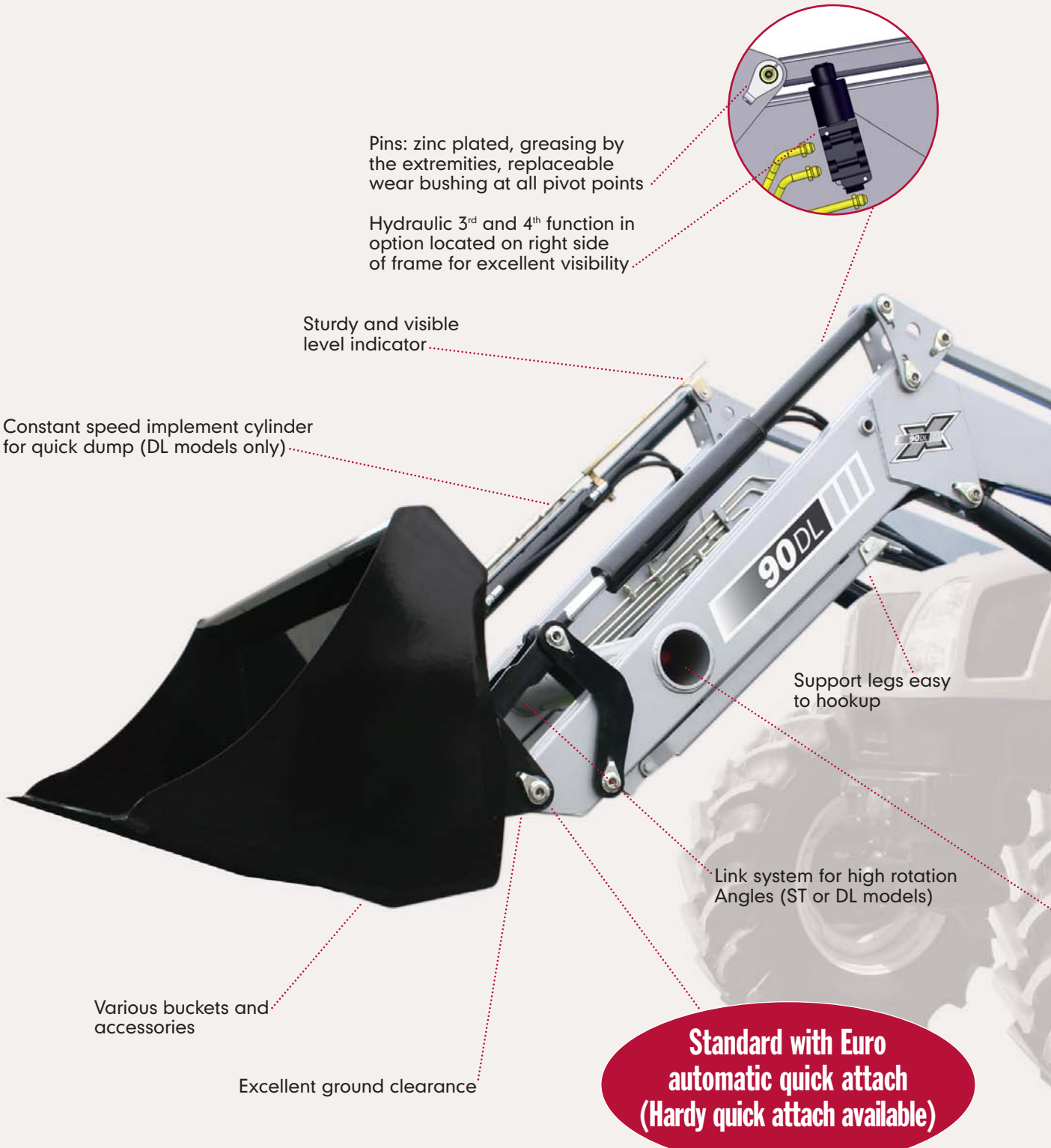

# Loader characteristics



Pins: zinc plated, greasing by the extremities, replaceable wear bushing at all pivot points

Hydraulic 3<sup>rd</sup> and 4<sup>th</sup> function in option located on right side of frame for excellent visibility

Sturdy and visible level indicator

Constant speed implement cylinder for quick dump (DL models only)

Support legs easy to hookup

Link system for high rotation Angles (ST or DL models)

Various buckets and accessories

Excellent ground clearance

**Standard with Euro automatic quick attach (Hardy quick attach available)**

**Exclusive**

120 DL HD and 130 DL HD models



ø 2" pins at each end of the frame

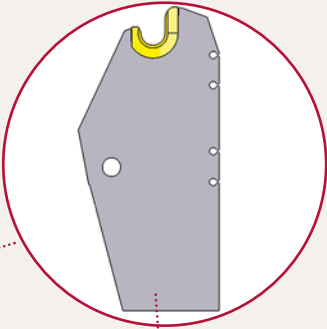
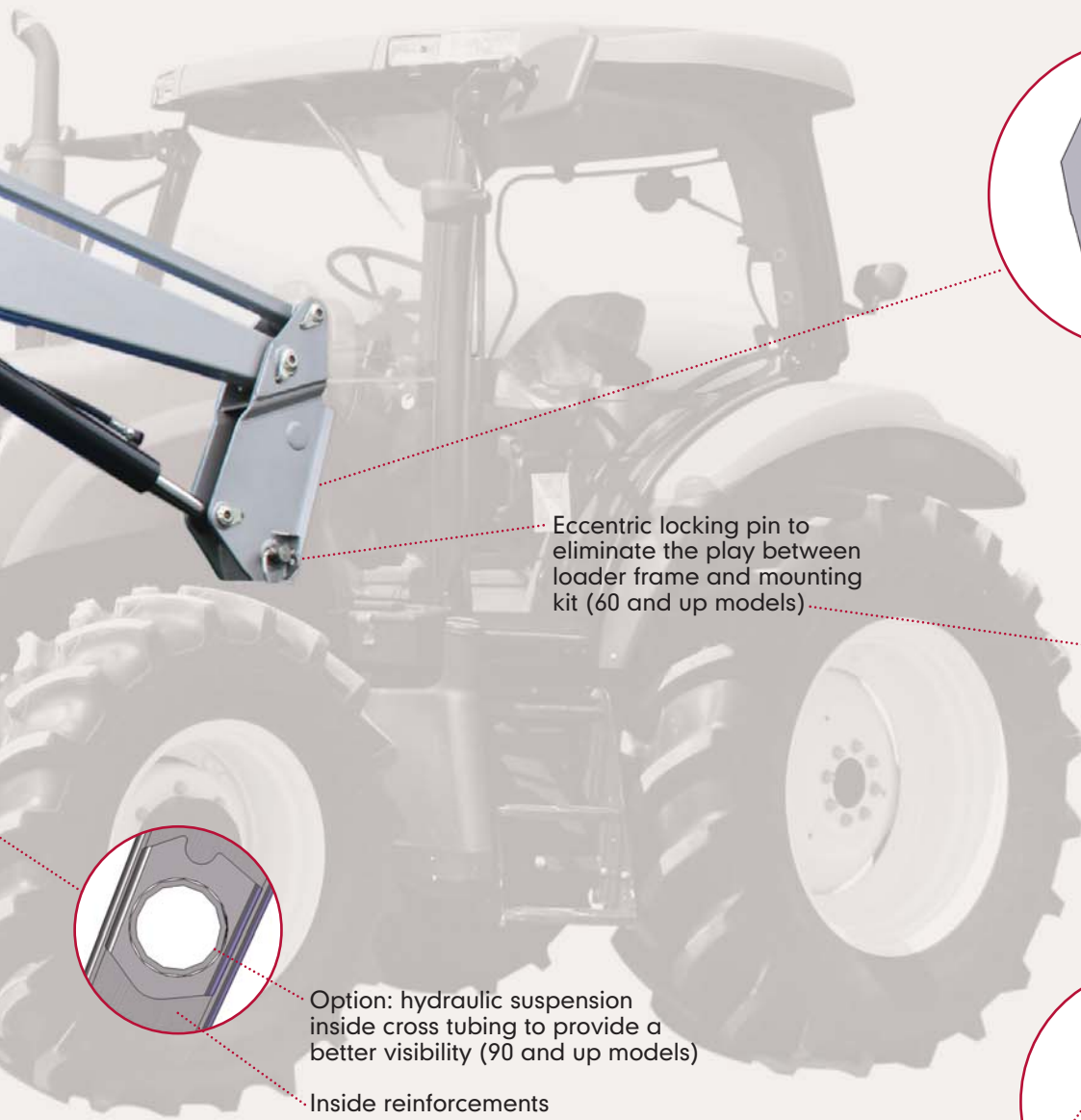

Sturdy mounting frame plate

Eccentric locking pin to eliminate the play between loader frame and mounting kit (60 and up models)

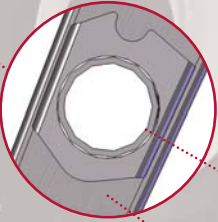
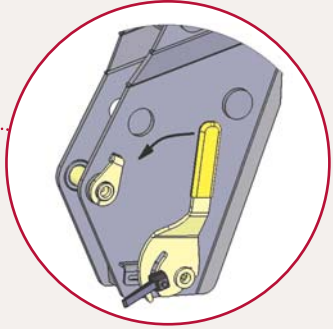

Option: hydraulic suspension inside cross tubing to provide a better visibility (90 and up models)

Inside reinforcements

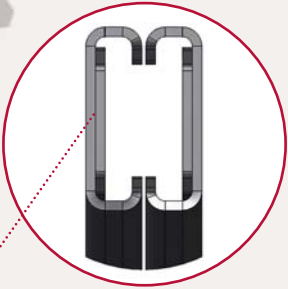

•  $\varnothing$  1 3/4" pins (other)

• Double plated frame (1/2" thick)

•  $\varnothing$  3 1/2" cylinders



## Versatility, performance, reliability.

**XTREMPRO** III

At the time of buying an agricultural loader, versatility, performance and reliability are essential qualities to consider. It is what offers you the new generation of loaders, XTREMPRO, developed by Hardy.

Ultra-efficient, the new loader XTREMPRO combines lifting speed, breakaway force, rugged design, operational safety, outstanding visibility which enhances operator's comfort and security, all in one single unit.

### Quick delivery\*

Select your XTREMPRO and choose the color by mentioning the make of your tractor. Your loader will be painted the same color without any extra charge.

\* Delivery time may vary depending on point of delivery and availability of mounting frame kit.



## An efficient resource in agriculture



### Power range

The new generation of XTREMPRO loaders are offered with power ranging between 30 and 170 HP, suiting all types of application.

### Unequaled visibility

Your XTREMPRO loader was designed to offer you an exceptional visibility.

In all circumstances, you will have a clear view of your accessories as well as your level indicator.



### Factory tested

The new generation of XTREMPRO loaders are tested in overpressure at our factory to insure their quality before expediting. All loaders are tested to guarantee your entire satisfaction!

# Snow removal



## Steel arms for snow removal

For snow removal, the new XTREMPRO tackles heavy burdens without hesitation. Fixed to your tractor, it will be very useful to scrape and move snow with matchless strength.

**XTREMPRO III**

### De luxe (DL) models loaded with advantages

- Automatic self-leveling control
  - Automatically maintains preset angle to the ground throughout its lifting cycle
  - Reduces the risk of lad spilling onto the tractor
- Increases lifting capacity compared to all other conventional models

# Landscaping



## The best value

No other loader on the market has as much characteristics as the XTREMPRO. The design of this new generation loader meets or exceeds all the industrial norms. As well as the expectations of professionals, just like you, who want performance for accurate work always well executed.



### The Heavy Duty XTREMPRO loader

For heavy duty work, choose the XTREMPRO HD option exclusive to Hardy. You will get more sturdiness for even more satisfaction!

# Loaders specifications



<b>A</b>
<b>B</b>
<b>C</b> **
<b>D</b>
<b>E</b>
<b>F</b>
<b>Capacity at arm center:</b>
At ground level
At full height
<b>Capacity at 31 1/2" from arm center:</b>
At ground level
At 60" from ground
At full height
<b>Tear-out force at 31 1/2":</b>
<b>Lift cylinder diameter</b>
<b>Bucket cylinder diameter</b>
<b>Diameter of boom pin</b>
<b>Diameter of lift cylinder pin</b>
<b>Diameter of other pins</b>
<b>Recommended tractor power ***</b>
<b>Loader weight (without bucket) (lbs./kg)</b>
<b>Lift time @ recommended flow</b>
<b>Recommended flow (gpm/l/min)</b>
<b>Recommended pressure (psi/bar)</b>
<b>Automatic levelling of the accessory</b>
<b>Excentric locking pin</b>
<b>Quick dump cylinder</b>
<b>Hydraulic protection of the bucket cyl.</b>
<b>Available accessories</b>
<b>Euro quick attach</b>
<b>Hardy quick attach</b>

40 ST		40 DL		50 ST		50 DL	
(in)	(m)	(in)	(m)	(in)	(m)	(in)	(m)
105	2.67	105	2.67	120	3.05	120	3.05
93 3/4	2.38	93 3/4	2.38	108 3/4	2.76	108 3/4	2.76
Variable		Variable		Variable		Variable	
40°		40°		41°		41°	
46°		46°		48°		48°	
X		57°		X		54°	
lbs.	kg	lbs.	kg	lbs.	kg	lbs.	kg
2500	1140	2500	1140	3500	1590	3500	1590
1350	610	1350	610	2150	980	2150	980
lbs.	kg	lbs.	kg	lbs.	kg	lbs.	kg
1550	700	1950	890	2250	1020	2550	1160
1250	570	1400	640	1850	840	1950	890
750	340	1250	570	1250	570	1800	820
lbs.	kg	lbs.	kg	lbs.	kg	lbs.	kg
2600	1180	2600	1180	2600	1180	2600	1180
(in)	(mm)	(in)	(mm)	(in)	(mm)	(in)	(mm)
2	51	2	51	2 1/4	57	2 1/4	57
2 1/4	57	2 1/4	57	2 1/4	57	2 1/4	57
1 1/4	32	1 1/4	32	1 1/4	32	1 1/4	32
1	25	1	25	1	25	1	25
1	25	1	25	1	25	1	25
30 @ 50 hp		30 @ 50 hp		40 @ 60 hp		40 @ 60 hp	
603	274	643	292	684	311	709	322
2.8 sec.		2.8 sec.		3.3 sec.		3.3 sec.	
8	30	8	30	10	38	10	38
2800	193	2800	193	2800	193	2800	193
N/D		■		N/D		■	
N/D		N/D		N/D		N/D	
N/D		□		N/D		□	
□		□		□		□	
LIGHT		LIGHT		LIGHT		LIGHT	
N/D		N/D		N/D		N/D	
MANUAL		MANUAL		MANUAL		MANUAL	

60 ST		60 DL		70 ST		70 DL	
(in)	(m)	(in)	(m)	(in)	(m)	(in)	(m)
134 3/4	3.42	134 3/4	3.42	146 3/4	3.73	146 3/4	3.73
118 1/4	3.00	118 1/4	3.00	130 1/2	3.31	130 1/2	3.31
Variable		Variable		Variable		Variable	
50°		50°		51°		51°	
56°		56°		58°		58°	
X		57°		X		62°	
lbs.	kg	lbs.	kg	lbs.	kg	lbs.	kg
4400	2000	4350	1980	5350	2430	5300	2410
3050	1390	3000	1360	4150	1890	4100	1860
lbs.	kg	lbs.	kg	lbs.	kg	lbs.	kg
2900	1320	3550	1610	3600	1640	4150	1890
2600	1180	2800	1270	3500	1590	3650	1660
1800	820	2450	1110	2600	1180	3200	1450
lbs.	kg	lbs.	kg	lbs.	kg	lbs.	kg
4450	2020	4450	2020	4450	2020	4450	2020
(in)	(mm)	(in)	(mm)	(in)	(mm)	(in)	(mm)
2 1/2	64	2 1/2	64	3	76	3	76
2 1/2	64	2 1/2	64	2 1/2	64	2 1/2	64
1 1/4	32	1 1/4	32	1 1/4	32	1 1/4	32
1	25	1	25	1 1/4	32	1 1/4	32
1	25	1	25	1	25	1	25
50 @ 80 hp		50 @ 80 hp		60 @ 90 hp		60 @ 90 hp	
885	402	931	423	957	435	1010	459
3 sec.		3 sec.		4 sec.		4 sec.	
16	60	16	60	16	60	16	60
2800	193	2800	193	2800	193	2800	193
N/D		■		N/D		■	
■		■		■		■	
N/D		■		N/D		■	
□		■		□		■	
REGULAR		REGULAR		REGULAR		REGULAR	
■		■		■		■	
□		□		□		□	

\*\* Changes according to tractor model. Call our technical department for a precise value according to tractor.

\*\*\* Approximate value. The choice of loader depends on size, weight, horsepower and available options of your tractor.

■ STANDARD  
□ OPTIONAL

## The color of your XTREMPRO harmonized to your tractor

What ever is the color of your tractor, we can paint your loader and accessories the same color. We offer a variety of colors suitable for your tractor, no matter the make. Here are a few examples:

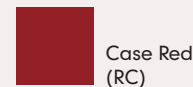
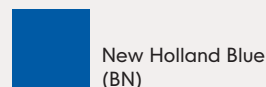
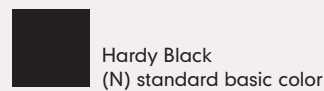



90 ST		90 DL		120 ST		120 DL		120 DL HD		130 ST		130 DL		130 DL HD	
(in)	(m)	(in)	(m)	(in)	(m)	(in)	(m)	(in)	(m)	(in)	(m)	(in)	(m)	(in)	(m)
158	4.01	158	4.01	170 1/2	4.33	170 1/2	4.33	170 1/2	4.33	182 3/4	4.64	182 3/4	4.64	182 3/4	4.64
142	3.61	142	3.61	154 1/4	3.92	154 1/4	3.92	154 1/4	3.92	166 1/2	4.23	166 1/2	4.23	166 1/2	4.23
Variable		Variable		Variable		Variable		Variable		Variable		Variable		Variable	
44°		44°		44°		44°		41°		43°		43°		40°	
59°		59°		61°		61°		61°		60°		60°		60°	
X		58°		X		56°		53°		X		54°		51°	
lbs.	kg	lbs.	kg	lbs.	kg	lbs.	kg	lbs.	kg	lbs.	kg	lbs.	kg	lbs.	kg
6700	3050	6650	3020	7600	3450	7550	3430	10000	4550	8350	3800	8300	3770	11000	5000
5050	2300	5000	2270	5500	2500	5450	2480	7250	3300	5550	2520	5500	2500	7400	3360
lbs.	kg	lbs.	kg	lbs.	kg	lbs.	kg	lbs.	kg	lbs.	kg	lbs.	kg	lbs.	kg
4700	2140	5550	2520	5450	2480	6200	2820	8300	3770	6150	2800	6800	3090	9100	4140
4400	2000	4700	2140	5000	2270	5200	2360	6900	3140	5400	2450	5600	2550	7400	3360
3300	1500	4200	1910	3700	1680	4500	2050	6100	2770	3900	1770	4700	2140	6300	2860
lbs.	kg	lbs.	kg	lbs.	kg	lbs.	kg	lbs.	kg	lbs.	kg	lbs.	kg	lbs.	kg
6900	3140	6900	3140	6900	3140	6900	3140	9200	4180	6900	3140	6900	3140	9200	4180
(in)	(mm)	(in)	(mm)	(in)	(mm)	(in)	(mm)	(in)	(mm)	(in)	(mm)	(in)	(mm)	(in)	(mm)
3	76	3	76	3	76	3	76	3 1/2	89	3	76	3	76	3 1/2	89
3	76	3	76	3	76	3	76	3 1/2	89	3	76	3	76	3 1/2	89
1 1/2	38	1 1/2	38	1 1/2	38	1 1/2	38	2	51	1 1/2	38	1 1/2	38	2	51
1 1/4	32	1 1/4	32	1 1/4	32	1 1/4	32	1 3/4	44	1 1/4	32	1 1/4	32	1 3/4	44
1 1/4	32	1 1/4	32	1 1/4	32	1 1/4	32	1 3/4	44	1 1/4	32	1 1/4	32	1 3/4	44
60 @ 100 hp	60 @ 100 hp	80 @ 130 hp	80 @ 130 hp	80 @ 130 hp	80 @ 130 hp	100 @ 150 hp	100 @ 150 hp	100 @ 150 hp	100 @ 150 hp	100 @ 150 hp	100 @ 150 hp	120 @ 170 hp	120 @ 170 hp		
1155	525	1225	557	1330	605	1405	639	1935	880	1432	651	1507	685	2075	943
5.2 sec.	5.2 sec.	6.1 sec.	6.1 sec.	6.7 sec.	6.7 sec.	7 sec.	7 sec.	7.6 sec.	7.6 sec.						
16	60	16	60	16	60	16	60	20	76	16	60	16	60	20	76
3000	207	3000	207	3000	207	3000	207	3000	207	3000	207	3000	207	3000	207
N/D	■	N/D	■	■	■	■	■	N/D	■	■	■	■	■		
■	■	■	■	■	■	■	■	■	■	■	■	■	■		
N/D	■	N/D	■	■	■	■	■	N/D	■	■	■	■	■		
□	■	□	■	■	■	■	■	□	■	■	■	■	■		
REGULAR	REGULAR	REGULAR	REGULAR	REGULAR	REGULAR	REGULAR	REGULAR	REGULAR	REGULAR	REGULAR	REGULAR	REGULAR	REGULAR		
■	■	■	■	■	■	■	■	■	■	■	■	■	■		
□	□	□	□	□	□	□	□	□	□	□	□	□	□		

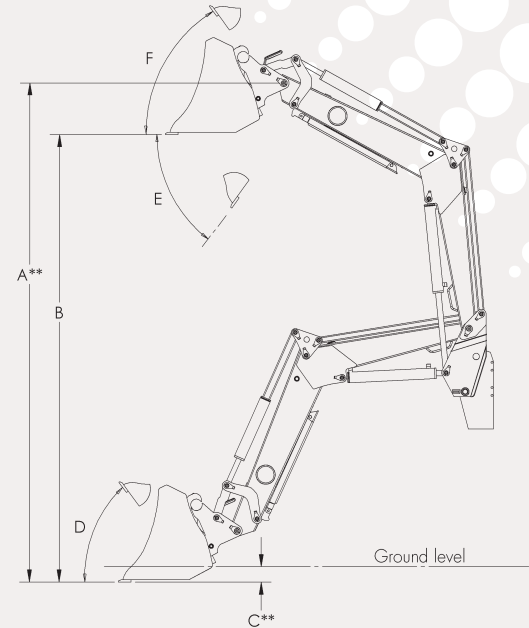

- Depending on tractor model, a counterweight might be necessary to assure good stability.
- Hardy reserves the right to modify these technical specifications without notice.

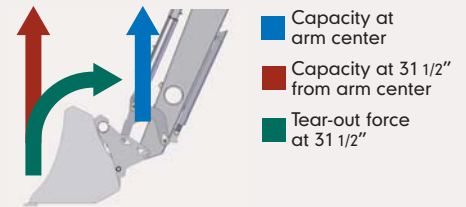

# Options

## Hydraulic suspension

Offers quick and easy manipulation while moving. It reduces the impact caused by the movement of the tractor, which reduces the stress to the frame while sparing the pins.

## Electro hydraulic joystick

This easy-to-use joystick in conjunction with an electro hydraulic valve provides the operator with greater precision and improved flexibility.

## Quick connect

Allows for one-step hydraulic system hookup and disconnection, therefore reducing potential coupling errors.

## Multipurpose hydraulic valve kit and joystick

This electro hydraulic valve mounted on the right side of the loader allows the operator to switch from one function to another from the operator's seat. Ideal for use with round bale clamp, hydraulic quick attach locking mechanism and pivoting snowplow blade.

# Sturdy accessories for all types of work

We fabricate a complete range of accessories that can be used in many applications. Their sturdiness has been tested and they are endowed with all the Hardy characteristics.



**MATERIAL BUCKET**



**MATERIAL BUCKET** (option: tines)

Description	Part #	Recommended loader	Width	Depth	Height	Weight	Capacity
Material bucket	25"A"-51-00	40-50xp	48" 1.22 m	19" 0.48 m	17" 0.43 m	190 lbs. 86 kg	0.20 v³ 0.15 m³
Material bucket	25"A"-52-00	40-50xp	54" 1.37 m	19" 0.48 m	17" 0.43 m	210 lbs. 95 kg	0.22 v³ 0.17 m³
Material bucket	25"A"-53-00	40-50xp	60" 1.52 m	19" 0.48 m	17" 0.43 m	230 lbs. 104 kg	0.24 v³ 0.18 m³
Material bucket	55"A"-53-00	60xp	60" 1.52 m	23" 0.56 m	25" 0.63 m	380 lbs. 172 kg	0.65 v³ 0.85 m³
Material bucket	55"A"-54-00	60 to 90xp	72" 1.83 m	28" 0.71 m	27" 0.69 m	500 lbs. 227 kg	0.75 v³ 0.96 m³
Material bucket	55"A"-55-00	120-130xp	84" 2.13 m	28" 0.71 m	27" 0.69 m	550 lbs. 250 kg	0.90 v³ 1.18 m³
Material bucket	55"A"-56-00	130xp	96" 2.44 m	28" 0.71 m	27" 0.69 m	620 lbs. 281 kg	1.00 v³ 1.31 m³

Available Euro or Hardy attachment. Other attachment on special order.



**MANURE BUCKET**

Description	Part #	Recommended loader	Width	Depth	Height	Weight	Capacity
Manure bucket	55"A"-58-00	60 to 90xp	60" 1.52 m	36" 0.91 m	25" 0.63 m	390 lbs. 177 kg	0.90 v³ 1.18 m³
Manure bucket	55"A"-59-00	90 to 130xp	72" 1.83 m	36" 0.91 m	25" 0.63 m	470 lbs. 213 kg	1.00 v³ 1.31 m³

Available Euro or Hardy attachment. Other attachment on special order.



**PALLET FORK** (option: bale spear)

Description	Part #	Recommended loader	Width	Depth	Height	Weight	Capacity
Pallet Fork	25"A"-70-00	40-50xp	49" 1.24 m	42" 1.07 m	20" 0.51 m	150 lbs. 68 kg	1500 lbs. 680 kg
Pallet Fork	55"A"-71-00	60 to 90xp	53" 1.35 m	48" 1.22 m	24" 0.61 m	280 lbs. 127 kg	3000 lbs. 1363 kg
Pallet Fork	55"A"-72-00	90 to 130xp	53" 1.35 m	48" 1.22 m	24" 0.61 m	380 lbs. 172 kg	5000 lbs. 2272 kg

Available Euro or Hardy attachment. Other attachment on special order.

# Ease up your task! Do your work with the high quality Hardy accessories

Your Hardy accessories fits perfectly to your XTREMPRO loader and to most loaders in the market.



**ROUND BALE GRAB**



**BALE SPEAR** (option: pallet fork)

Description	Part #	Recommended loader	Width	Depth	Height	Weight	Capacity
Round bale grab	55"A"-68-00	60 to 130xp	54" 1.37 m	54" 1.37 m	30" 0.76 m	390 lbs. 177 kg	3' to 6' dia. 0.9 to 1.8 m
Bale spear	55"A"-69-00	60 to 130xp	53" 1.35 m	39" 0.99 m	20" 0.51 m	140 lbs. 63 kg	2500 lbs. 1134 kg

Available Euro or Hardy attachment. Other attachment on special order.



**SNOW BUCKET**

Description	Part #	Recommended loader	Width	Depth	Height	Weight	Capacity
Snow Bucket	25"A"-62-00	40-50xp	60" 1.52 m	24" 0.61 m	24" 0.61 m	280 lbs. 127 kg	0.50 v³ 0.38 m³
Snow Bucket	55"A"-63-00	60xp	72" 1.83 m	30" 0.76 m	32" 0.81 m	710 lbs. 322 kg	1.25 v³ 1.64 m³
Snow Bucket	55"A"-64-00	70 to 130xp	84" 2.13 m	30" 0.76 m	32" 0.81 m	760 lbs. 345 kg	1.50 v³ 1.96 m³
Snow Bucket	55"A"-65-00	90 to 130xp	84" 2.13 m	36" 0.91 m	38" 0.97 m	880 lbs. 400 kg	2.00 v³ 2.62 m³
Snow Bucket	55"A"-66-00	130xp	96" 2.44 m	36" 0.91 m	38" 0.97 m	1040 lbs. 472 kg	2.50 v³ 3.27 m³

Available Euro or Hardy attachment. Other attachment on special order.



**SNOW BLADE**

Over 30 models available with and without tripping system.

# Other products

Many other products are available on our web sites at: [www.gohardy.com](http://www.gohardy.com)  
[www.pronovost.qc.ca](http://www.pronovost.qc.ca)

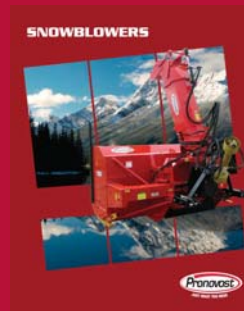
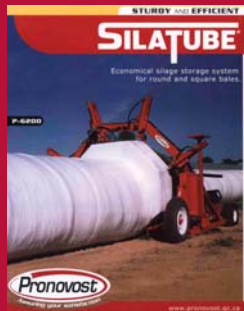
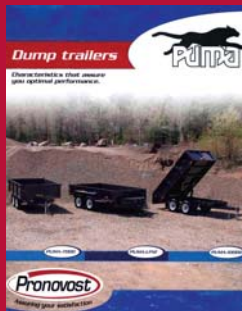
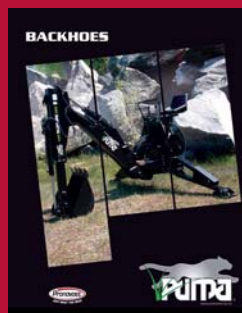
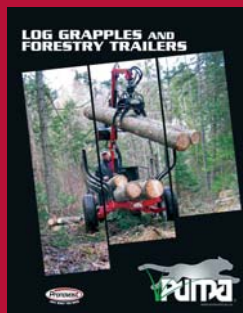

**Hardy Equipment inc.**  
 100 rue St-Arthur, Notre-Dame-de-Portneuf  
 (Québec) Canada G0A 2Z0  
 Tel.: (418) 286-6621 Fax: (418) 286-3733  
 1 877 994-2739  
[info@gohardy.com](mailto:info@gohardy.com) [www.gohardy.com](http://www.gohardy.com)